

## Description

This is an internal removable thermodynamic steam trap with forged carbon steel body. The module valve seat is inline replaceable.

Note: The Integral Blow-down valve is an assembly designed to be fitted to 772 Thermodynamic steam traps as an extra option.



## Limiting Conditions

Maximum Body Design Conditions	PN 50
PMO - Maximum Operating Pressure	42 kgf/cm <sup>2</sup>
TMO - Maximum Operating Temperature	400 °C
PMOB - Maximum Operating Back Pressure - not exceed	75% of Inlet Pressure
Minimum Operating Differential Pressure for Satisfactory Operation	1 kgf/cm <sup>2</sup>
PMA - Maximum Allowable Pressure	50 kgf/cm <sup>2</sup>
TMA - Maximum Allowable Temperature	400 °C
Cold Hydraulic Test Pressure	75 kgf/cm <sup>2</sup>

## Operating Range

$\Delta PMX$  – Maximum differential pressure 42 kgf/cm<sup>2</sup>

## Sizes and Pipe Connections

1/2", 3/4" and 1" Flanged (ANSI B16.5)

## Dimensions / Weights (Approximate) mm and kg

Size	A	B	Flange					
			150#		300#		600#	
			C	Weight	C	Weight	C	Weight
1/2"	70	80	150	2	160	2.5	170	3
3/4"	75	90	150	3	160	3.5	170	4
1"	80	90	160	4	170	4.5	180	5

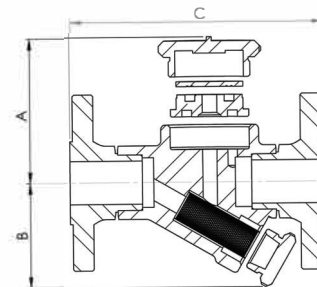

Constructions are a bit different according the sizes.



E.S.E. Valve Co. Ltd.

021 66479486  
0912 8448763

فروش

E.S.E. Valve Co.

## Flanged Internal Removable Thermodynamic Steam Traps – 772

### Materials

No.	Part	Material
1	Body	ASTM A105
2	Valve Seat *	AISI 420
3	Disc *	AISI 420
4	Cap	AISI 420
5	Strainer Screen *	AISI 304/316
6	Strainer Cap	AISI 420
7	Flange	ASTM A105
8	Name Plate	ALUMINUM
9	Blow-Down Cap **	AISI 420
10	Blow-Down Screw **	AISI 420

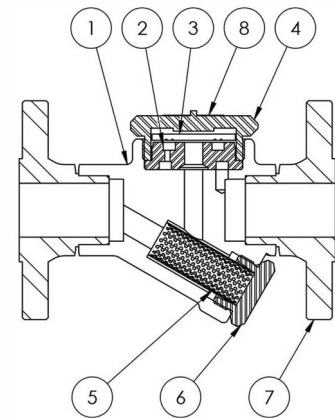

Note: (\*) Spare Part  
(\*\*) Optional extra

### Capacities

Maximum continual discharge amount (kg/h)

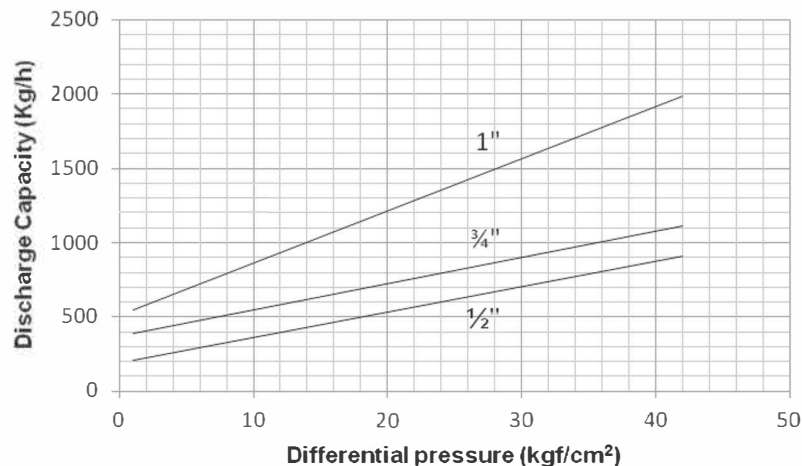

### Installation

The trap should preferably be installed in the horizontal plane, with a small drop leg preceding it. Where the trap discharges into a closed return system, a non-return valve should be fitted downstream to prevent return flow. Ensure all connection ports are clear from obstruction. Always open isolation valves slowly until normal operating conditions are achieved. This will avoid system shocks. Check for leaks and correct operation. Always ensure the correct tools, safety procedures and protective equipment are used at all times.

### How to Order

Example: TD772 1/2", Flanged Thermodynamic Steam Trap with Blow-down Valve.

Design and specification are subject to change without notice